

STANLEY®



MATERIAL HANDLING

2022 CATALOG



OUR MATERIAL HANDLING RANGE IS AVAILABLE IN VARIOUS OPTIONS!

SP
FCB
Pdq

Single Packed carton box
Full Color carton box
Ready-To-Sell Product Displays

Look out for the options in the product spec tables!

INDEX

4

FOLDING HAND TRUCKS

05 SXWT-FT585

07 SXWT-FT505

07 SXWT-FT509

07 SXWT-FT591

08 SXWT-FT580

08 SXWT-FT581

09 SXWT-FT582

09 SXWT-FT584

10 SXWT-FT516

10 SXWT-FT500

10 SXWT-FT501

11 SXWT-FT591

12 FXWT-705

12 FXWT-706

12 FXWT-507

12

STEEL HAND TRUCKS & MULTI TRUCKS

13 SXWT-FT520

13 SXWT-FT521

14 SXWT-HT523

14 SXWT-HT524

14 SXWT-HT525

15 SXWT-MT519

16 SXWT-HT522

16 SXWT-HT526

16 SXWT-HT535

17 SXWT-HT537

17 SXWT-HT538

17 SXWT-HT539

18 SXWT-HT513

18 SXWT-HT514

19 SXWT-MT515

20

PLATFORM TRUCKS

21 SXWT-PC517

21 SXWT-PC519

22 SXWT-PC527

22 SXWT-PC527P

22 SXWT-PC528

23 SXWT-PC508

23 SXWT-PC509

23 SXWT-PC510

23 SXWT-PC511

23 SXWT-PC512

24 SXWT-MS572

24 SXWT-MS573

26 SXWT-PC531

26 SXWT-PC531B

27 SXWT-PC532

27 SXWT-PC532B

28

FATMAX TRUCKS

28 FXWT-712

29 FXWT-711

29 FXWT-704

30 FXWT-705

30 FXWT-706

30 FXWT-707

31 FXWT-700

31 FXWT-701

31 FXWT-702



FOLDING HAND TRUCKS

Our latest STANLEY® Folding Trucks combine the best of both worlds. Strong steel tubing ensures durability and load capacity. The rugged black load plate is cast from aluminum to keep the weight down. Solid TPR wheels run smoothly, quietly, and can't spring a leak. Best of all: every truck folds down to easily fit in the trunk of any car.

2-IN-1 FOLDING TRUCK

Easy-to-Use Versatile Utility Cart
 Strong and Durable Design
 Made of strong and durable steel
 Takes Seconds to Open and Close
 Major plastic stress points are made of durable nylon;
 other plastic pieces are polypropelene
 Hand truck and platform cart in one

SXWT-FT585

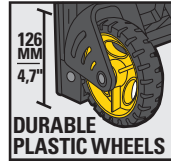

PRODUCT CODE	BARCODE	CAPACITY	WEIGHT	FOLDED / PLATFORM / HAND TRUCK DIMENSIONS	BASE PLATE / PLATFORM	WHEELS
SXWT-FT585-SP	871496637642	70 / 137 KG	7,4 KG	389 MM X 117 MM X 643 MM	388 MM X 231 MM 571 MM X 382 MM	127 MM
SXWT-FT585-PDQ	8717496635853			780 MM X 450 MM X 920 MM 450 MM X 416 MM X 1100 MM		86,6 MM TPR+PP

PDO PACKAGING



DISCOVER OUR
READY-TO-SELL
PRODUCT DISPLAYS
FILLED WITH OUR
HAND TRUCKS &
PLATFORM CARTS
AND GET INSTANT SALES!



FOLDING UTILITY BASKET

Ideal for use SXWT-FT501, SXWT-PC517,
SXWT-PC531 and FXWT-711
Versatile utility basket folds and opens in seconds
Compact design - for easy storage almost anywhere
Made of lightweight and durable polypropylene

Pins on the bottom allow the baskets to be stacked on each other
Retractable placement pins allow for easy
and stable double or triple stacking

SXWT-FT505

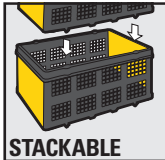
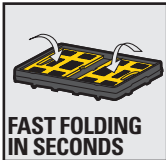

PRODUCT CODE	BARCODE	CAPACITY	WEIGHT	FOLDED / UNFOLDED DIMENSIONS	VOLUME
SXWT-FT505-SP	8717496637581	25 KG	1,8 KG	568 MM X 410 MM X 75 MM	40 L
SXWT-FT505-PDQ	8717496635051			568 MM X 410 MM X 272 MM	

COMBI PACK

This Combi Pack includes the SXWT-FT501 Folding Hand Truck
and SXWT-FT505 Folding Utility Basket

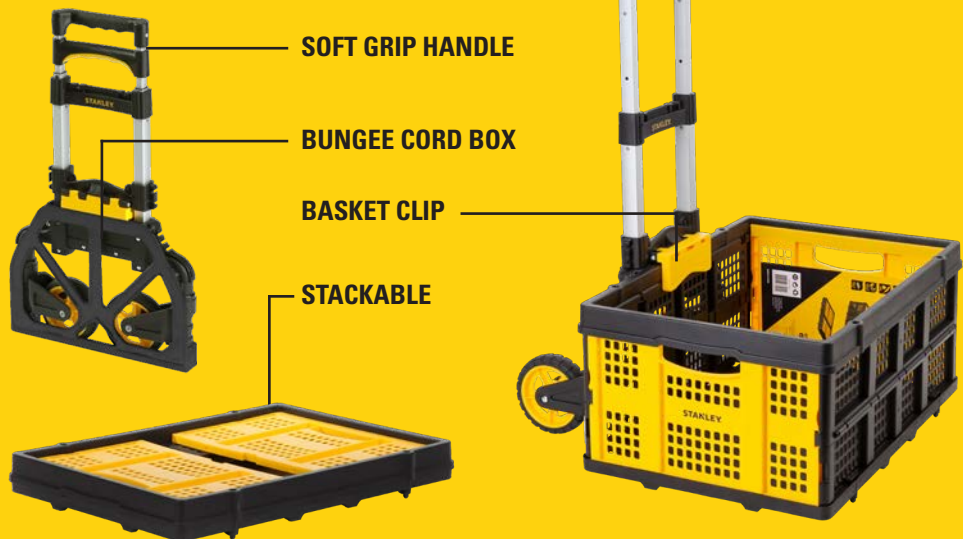
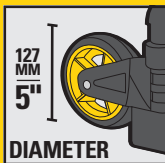
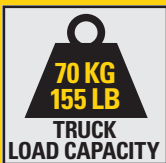

PRODUCT CODE	BARCODE	CAPACITY	WEIGHT	FOLDED / UNFOLDED DIMENSIONS	BASE PLATE SIZE	WHEELS
SXWT-FT509-SP	8717496637826	70 / 25 KG	4 KG	SEE SPECIFICATIONS OF SXWTD-FT501 AND SXWTD-FT505	390 MM X 280 MM	127 MM TPR+PP
SXWT-FT509-FCB	8717496637826					

FOLDING HAND TRUCKS

Folds and opens in seconds. Easy to Use and Store
 Comes 100% fully assembled
 Made of strong durable steel
 Major plastic stress points are made of durable nylon;
 other pieces are polypropylene

Adjustable TPR grip handle
 Comes with a bungee cord to safely strap loads onto the hand truck

SXWT-FT580

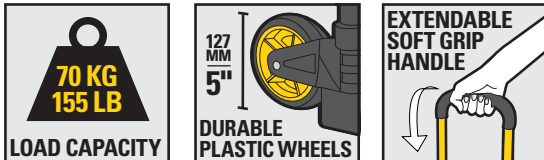

SXWT-FT581

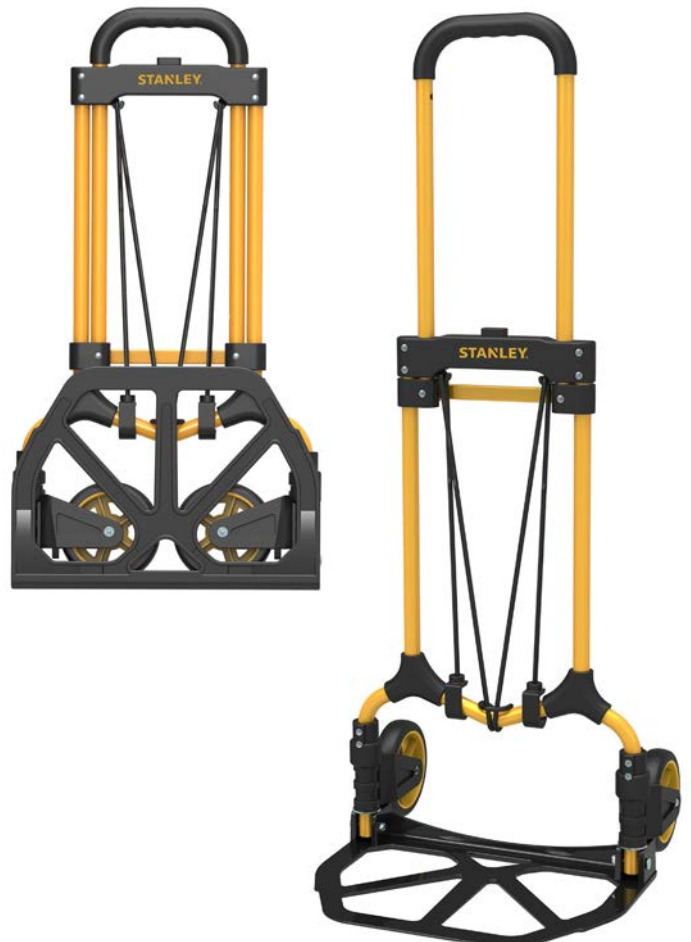
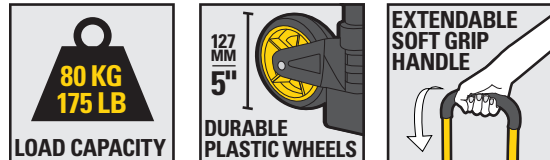

PRODUCT CODE	BARCODE	CAPACITY	WEIGHT	FOLDED / UNFOLDED DIMENSIONS	BASE PLATE SIZE	WHEELS
SXWT-FT580-SP	8717496637598	70 KG	3,9 KG	390 MM X 60 MM X 730 MM 400 MM X 420 MM X 1020 MM	390 MM X 290 MM	127 MM TPR+PP
SXWT-FT580-PDQ	8717496635808					
SXWT-FT581-SP	8717496638755	80 KG	4,9 KG	390 MM X 60 MM X 730 MM 400 MM X 420 MM X 1020 MM	390 MM X 290 MM	127 MM TPR+PP
SXWT-FT581-PDQ	8717496638762					

FOLDING HAND TRUCKS

Folds and opens in seconds. Easy to Use and Store
 Comes 100% fully assembled
 Made of strong durable steel
 Major plastic stress points are made of durable nylon;
 other pieces are polypropylene

Adjustable TPR grip handle
 Comes with a bungee cord to safely strap loads onto the hand truck

SXWT-FT584: The wheels make sure it is easy to maneuver on stairs, thresholds, curbstones and other obstacles.

SXWT-FT582

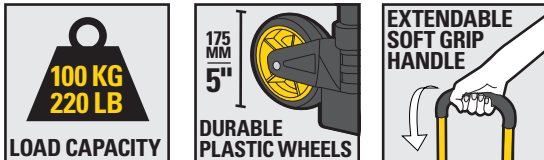

SXWT-FT584



PRODUCT CODE	BARCODE	CAPACITY	WEIGHT	FOLDED / UNFOLDED DIMENSIONS	BASE PLATE SIZE	WHEELS
SXWT-FT582-SP	8717496637604	100 KG	4,75 KG	500 MM X 65 MM X 740 MM 500 MM X 450 MM X 980 MM	490 MM X 280 MM	175 MM TPR+PP
SXWT-FT582-PDQ	8717496635822					
SXWT-FT584-SP	8717496637611	30 / 60 KG	3,5 KG	390 MM X 67 MM X 725 MM 410 MM X 410 MM X 1020 MM	390 MM X 290 MM	3X 55 MM TPR+PP
SXWT-FT584-PDQ	8717496635846					

FOLDING HAND TRUCKS

Folds and opens in seconds
 Easy to use and store and comes 100% fully assembled
 Compact design made of lightweight and durable aluminum
 Major plastic stress points made of durable plastic
 Soft grip handle for added comfort

Includes elastic bungee cord in built in storage container
 Compact design - for easy storage almost anywhere
 Silent TPR wheels

SXWT-FT501: Compatible with SXWT-FT505 Folding Basket

SXWT-FT516

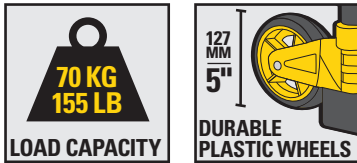

SXWT-FT500

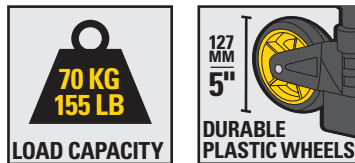

SXWT-FT501

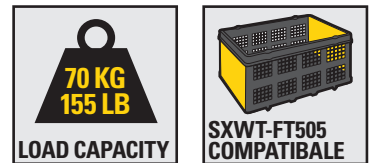

PRODUCT CODE	BARCODE	CAPACITY	WEIGHT	FOLDED / UNFOLDED DIMENSIONS	BASE PLATE SIZE	WHEELS
SXWT-FT516-SP	8717496638052	70 KG	3,1 KG	385 MM X 56 MM X 635 MM 400 MM X 410 MM X 1000 MM	390 MM X 280 MM	127 MM PR+PP
SXWT-FT516-PDQ	8717496635167					
SXWT-FT500-SP	8717496638038	70 KG	3,1 KG	385 MM X 56 MM X 635 MM 400 MM X 410 MM X 1000 MM	390 MM X 280 MM	127 MM TPR+PP
SXWT-FT500-PDQ	8717496635006					
SXWT-FT501-SP	8717496638045	70 KG	3,3 KG	385 MM X 56 MM X 635 MM 400 MM X 410 MM X 1000 MM	390 MM X 280 MM	127 MM TPR+PP
SXWT-FT501-PDQ	8717496635013					

FOLDING HAND TRUCK

Folds and opens in seconds. Easy to Use and Store
 Comes 100% fully assembled
 Made of strong durable PP and steel
 Major plastic stress points are made of durable nylon;
 other pieces are polypropylene

SXWT-FT591

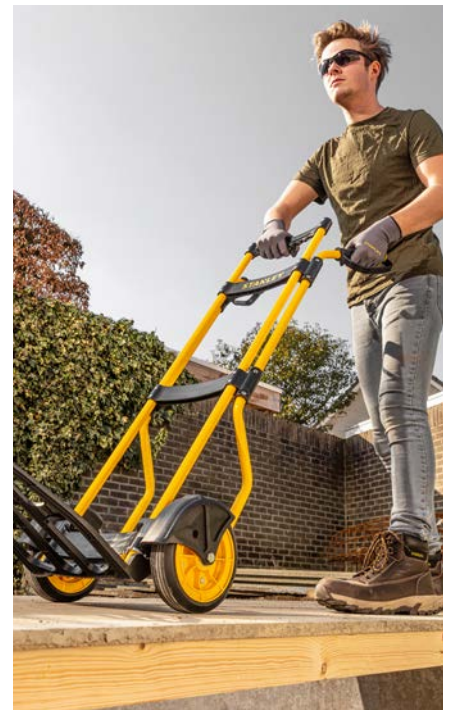
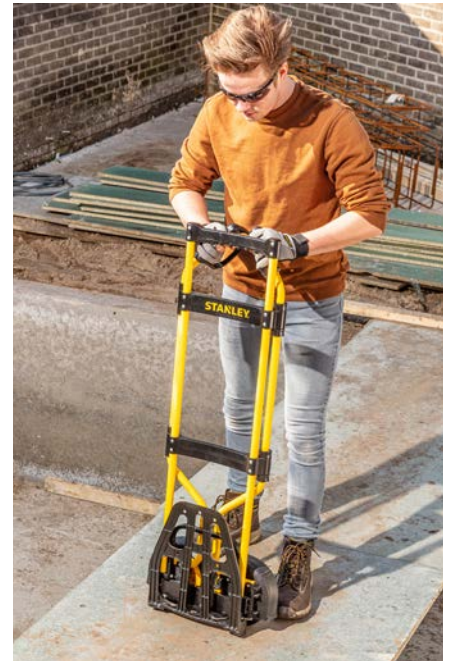
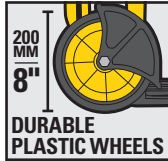

PRODUCT CODE	BARCODE	CAPACITY	WEIGHT	HAND TRUCK DIMENSIONS	BASE PLATE / PLATFORM	WHEELS
SXWT-FT591	8717496637659	270 KG	8 KG	1170 MM X 158 MM X 450 MM	333 MM X 307 MM	200 MM TPE



STEEL HAND TRUCKS & MULTI TRUCKS

Designed for the challenges of real working environments, every STANLEY® truck combines user friendly features with rugged build quality for safe, easy and secure moving, whatever the load. STANLEY® trucks are designed from the ground upwards; choose from different chassis types, capacities and lifting capabilities to provide you with the ideal STANLEY® truck for the job.

STEEL FOLDING HAND TRUCKS

Made of tough steel for added strength and durability
 Top frame slides into bottom frame for convenient storage and include knuckle protection
 Move heavy loads, boxes, furniture easily and safely
 Ergonomic handles with knuckle covers

SXWT-FT520: Large pneumatic wheels allow for easy movement
 Available with both pneumatic and solid PU wheels

SXWT-FT521: 3-wheeled design for easy movement over obstacles, thresholds and stairs

SXWT-FT520

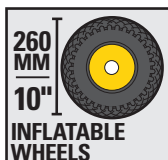
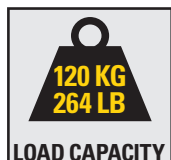

SXWT-FT521

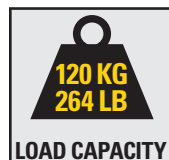

PRODUCT CODE	BARCODE	CAPACITY	WEIGHT	FOLDED / UNFOLDED DIMENSIONS	BASEPLATE SIZE	WHEELS
SXWT-FT520	8717496635204	120 KG	11 KG	280 MM X 480 MM X 800 MM 520 MM X 480 MM X 1130 MM	310 MM X 290 MM	260 MM PNEUMATIC
SXWT-FT520-PU	8717496637536					260 MM SOLID PU
SXWT-FT521	8717496635211	120 KG	15 KG	430 MM X 480 MM X 800 MM 660 MM X 480 MM X 1130 MM	310 MM X 290 MM	3X 150 MM TPR

STEEL HAND TRUCKS

Made of tough steel for added strength and durability
 Move heavy loads, boxes, furniture easily and safely
 Ergonomic handles with knuckle covers
 Available with both pneumatic and solid PU wheels
SXWT-FT523: 3-wheeled design for easy movement over obstacles, thresholds and stairs

SXWT-FT524: Built in guides on the back allow for easier handling on stairways

SXWT-FT525: Commercial hand truck with all lightweight aluminum construction Built in guides on the back allow for easier handling on stairways

SXWT-HT523



SXWT-HT524

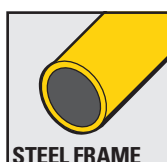
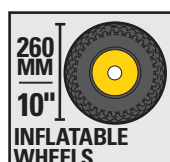

SXWT-HT525

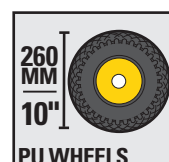

PRODUCT CODE	BARCODE	CAPACITY	WEIGHT	OVERALL DIMENSIONS	BASEPLATE SIZE	WHEELS
SXWT-HT523	8717496635235	200 KG	13,8 KG	590 MM x 520 MM x 1190 mm	305 MM X 240 MM	3X 150 MM PP
SXWT-HT524	8717496635242	250 KG	9,8 KG	490 MM X 550 MM X 1190 MM	305 MM X 240 MM	260 MM PNEUMATIC
SXWT-HT524-PU	8717496637499					260 MM SOLID PU
SXWT-HT525	8717496635259	200 KG	8,4 KG	480 MM X 510 MM X 1180 MM	400 MM X 205 MM	260 MM PNEUMATIC
SXWT-HT525-PU	8717496637505					260 MM SOLID PU

STEEL MULTI TRUCK

Easy and secure handling with this steel hand truck and extra large loading platform for commercial use. Made of durable steel. Guides on the back allow for easy handling on large obstacles like stairs. Large pneumatic wheels allow for easy movement in indoor and outdoor situations. Move your heavy loads, boxes, furniture easy and safely. Heavy duty castors allow for precise steering in platform modus. Available with both pneumatic and solid PU wheels

SXWT-MT519

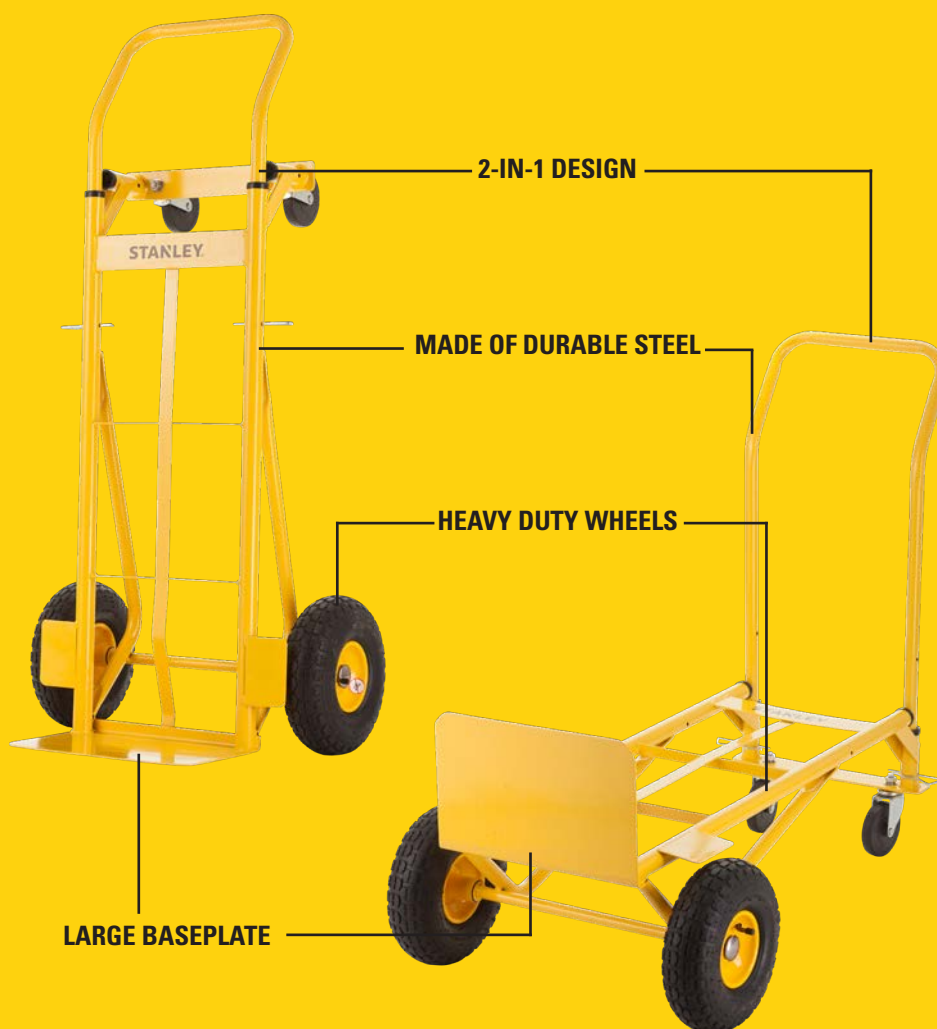
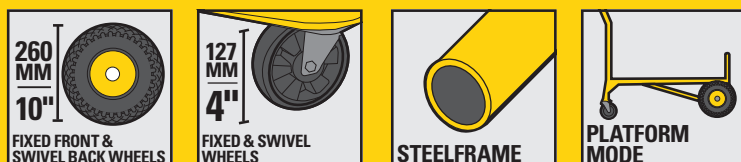

PRODUCT CODE	BARCODE	CAPACITY	WEIGHT	OVERALL DIMENSIONS	LOADPLATE SIZE	WHEELS
SXWT-MT519	8717496635198	150 / 200 KG	13,6 KG	460 MM X 580 MM X 1435 MM	355 MM X 850 MM	260 MM PNEUMATIC
SXWT-MT519-PU	8717496637550					260 MM SOLID PU

STEEL HAND TRUCKS

Commercial hand trucks with durable all steel construction

Ergonomic handles with knuckle covers

Available with both pneumatic and solid PU wheels

Move heavy loads, boxes and furniture indoors or outdoors easily and safely

| SXWT-HT535: Includes 100% assembled folding platform

SXWT-HT522



SXWT-HT526



SXWT-HT535



PRODUCT CODE	BARCODE	CAPACITY	WEIGHT	OVERALL DIMENSIONS	BASEPLATE SIZE	WHEELS
SXWT-HT522	8717496635228	200 KG	9,7 KG	520 MM X 490 MM X 1190 MM	355 MM X 240 MM	260 MM PNEUMATIC
SXWT-HT522-PU	8717496637543					260 MM SOLID PU
SXWT-HT526	8717496635266	300 KG	11,1 KG	465 MM X 620 MM X 1180 MM	400 MM X 195 MM	260 MM PNEUMATIC
SXWT-HT526-PU	8717496637512					260 MM SOLID PU
SXWT-HT535	8717496635358	200 KG	11,6 KG	440 MM X 590 MM X 1100 MM 780 MM X 600 MM X 1100 MM	420 MM X 155 MM	260 MM PNEUMATIC
SXWT-HT535-PU	8717496637529					260 MM SOLID PU

STEEL P-HANDLE HAND TRUCKS

Commercial hand trucks with durable all steel construction
 Plastic handles provide better grip and include knuckle protection
 Available with both pneumatic and solid PU wheels
 Move heavy loads, boxes and furniture indoors or outdoors easily and safely

| SXWT-HT539: Includes click-on load protectors

SXWT-HT537

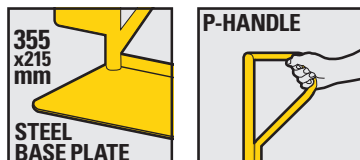

SXWT-HT538

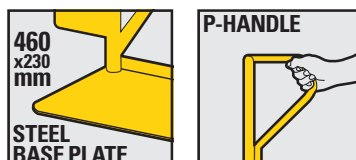

SXWT-HT539

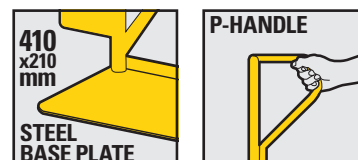

PRODUCT CODE	BARCODE	CAPACITY	WEIGHT	OVERALL DIMENSIONS	BASEPLATE SIZE	WHEELS
SXWT-HT537	8717496635372	200 KG	9,6 KG	480 MM X 545 MM X 1310MM	355 MM X 215 MM	260 MM PNEUMATIC
SXWT-HT537-PU	8717496635372					260 MM SOLID PU
SXWT-HT538	8717496635389	300 KG	13 KG	480 MM X 590 MM X 1320 MM	460 MM X 230 MM	260 MM PNEUMATIC
SXWT-HT539	8717496635396	360 KG	13,6 KG	540 MM X 580 MM X 1310 MM	410 MM X 210 MM	260 MM PNEUMATIC

ALUMINUM HAND TRUCKS

Industrial quality aluminum hand truck

Light and durable aluminum construction for added durability whilst minimising weight

Large pneumatic wheels allows for easy movement indoors and outdoors

Includes extra large foldable platform for heavy and oversized loads and special guide on the back to use on stairs

Ideal for industrial use in factories, commercial warehouses, retail stores, delivery services and professional movers

SXWT-HT513

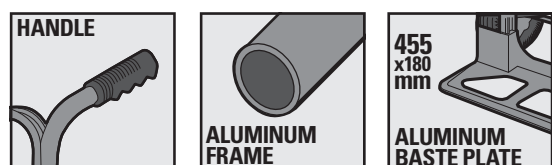

SXWT-HT514



PRODUCT CODE	BARCODE	CAPACITY	WEIGHT	OVERALL DIMENSIONS	BASEPLATE SIZE	WHEELS
SXWT-HT513	8717496635136	200 KG	10 KG	510 MM X 470 MM X 1230 MM	455 MM X 180 MM	260 MM PNEUMATIC
SXWT-HT514	8717496635143	200 KG	13 KG	510 MM X 470 MM X 1230 MM 510 MM X 800 MM X 1230 MM	455 MM X 180 MM 455 MM X 500 MM	260 MM PNEUMATIC

ALUMINUM MULTI TRUCK

Easy and secure handling with this aluminum hand truck and extra large loading platform for commercial use. Made of durable aluminum. Guides on the back allow for easy handling on large obstacles like stairs. Large pneumatic wheels allow for easy movement in indoor and outdoor situations. Move your heavy loads, boxes, furniture easy and safely. Heavy duty castors allow for precise steering in platform modus.

SXWT-MT515



PRODUCT CODE	BARCODE	CAPACITY	WEIGHT	PLATFORM / HAND TRUCK DIMENSIONS	BASEPLATE SIZE	WHEELS
SXWT-MT515	8717496635150	200 / 250 KG	17 KG	1180 MM X 510 MM X 1030 MM 470 MM X 510 MM X 1320 MM	450 MM X 180 MM	260 MM PNEUMATIC 127 MM CASTERS



PLATFORM TRUCKS

Designed for the challenges of real working environments, every STANLEY® truck combines user friendly features with rugged build quality for safe, easy and secure moving, whatever the load.

STANLEY® trucks are designed from the ground upwards; choose from different chassis types, capacities and lifting capabilities to provide you with the ideal STANLEY® truck for the job.

FLAT-FOLDING TRUCKS

4-wheeled professional platform truck, folds and opens in seconds
 Robust design made of lightweight and durable aluminum and polypropylene
 Soft grip telescopic handle for secure maneuvering of loads
 Built for commercial warehouses, retail stores, delivery services and professional movers
 Soft grip handle, platform with basket pin slots

SXWT-PC517

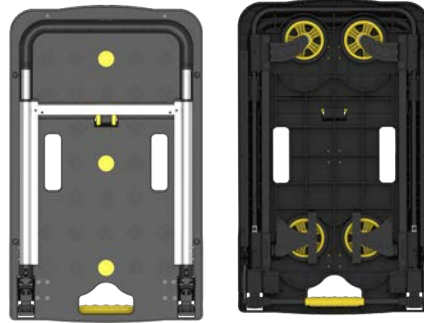
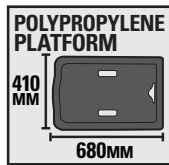

PRODUCT CODE	BARCODE	CAPACITY	WEIGHT	FOLDED / UNFOLDED DIMENSIONS	PLATFORM SIZE	WHEELS
SXWT-PC517-SP	8717496637635	120 KG	6,4 KG	680 MM X 410 MM X 80 MM	680 MM X 410 MM	100 MM TPR
SXWT-PC517-PDQ	8717496635174			680 MM X 410 MM X 920 MM		

COMBI PACK

This Combi Pack includes the SXWT-PC517 Flat-Folding Platform Truck and SXWT-FT505 Folding Utility Basket

SXWT-PC519

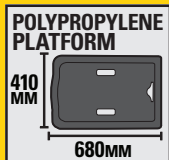

PRODUCT CODE	BARCODE	CAPACITY	WEIGHT	FOLDED / UNFOLDED DIMENSIONS	PLATFORM SIZE	WHEELS
SXWT-PC519-SP	8717496638748	120 / 25 KG	8,5 KG	SEE SPECIFICATIONS OF SXWTD-PC517 AND SXWTD-FT505	680 MM X 410 MM	75 MM TPR
SXWT-PC519-PDQ	8717496638021					

FOLDING PLATFORM TRUCK

- Steel platform truck folds and opens in seconds
- Tubing and platform made of tough steel for added durability
- Strong, rigid, steel handle for secure maneuvering of loads
- 4 ball bearing wheels for easy and safe steering (NOT SXWT-PC527P)
- Compact design for easy storage

SXWT-PC527

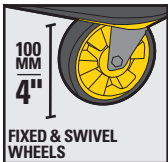

SXWT-PC527P

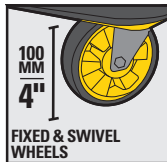

SXWT-PC528

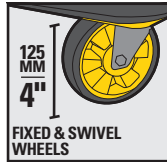

PRODUCT CODE	BARCODE	CAPACITY	WEIGHT	FOLDED / UNFOLDED DIMENSIONS	PLATFORM SIZE	WHEELS
SXWT-PC527	8717496635273	150 KG	7,7 KG	735 MM X 470 MM X 230 MM	735 MM X 470 MM	100 MM BALL BEARING
SXWT-PC527P	8717496635655			735 MM X 470 MM X 830 MM		100 MM PLAIN BEARING
SXWT-PC528	8717496635280	300 KG	14 KG	910 MM X 610 MM X 280 MM 910 MM X 610 MM X 870 MM	910 MM X 610 MM	125 MM BALL BEARING

COMMERCIAL TRUCKS

4-wheeled professional platform truck, folds and opens in seconds
 Robust design made of lightweight and durable polypropylene
 Strong steel rigid handle for secure maneuvering of loads
 Built for commercial warehouses, retail stores, delivery services and professional movers

SXWT-PC508

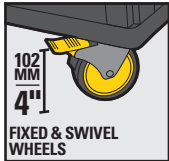

SXWT-PC509

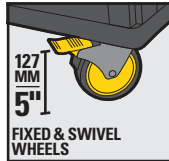

PRODUCT CODE	BARCODE	CAPACITY	WEIGHT	FOLDED / UNFOLDED DIMENSIONS	PLATFORM SIZE	WHEELS
SXWT-PC508	8717496635082	150 KG	8,5 KG	740 MM X 470 MM X 270 MM 740 MM X 470 MM X 930 MM	740 MM X 470 MM	102 MM TPR
SXWT-PC509	8717496635099	250 KG	13 KG	900 MM X 610 MM X 290 MM 900 MM X 610 MM X 940 MM	900 MM X 610 MM	127 MM TPR

INDUSTRIAL TRUCKS

4-wheeled professional platform truck, folds and opens in seconds
 Robust design made of lightweight and durable polypropylene
 Strong steel rigid handle for secure maneuvering of loads
 Built for commercial warehouses, retail stores, delivery services and professional movers

SXWT-PC510



SXWT-PC511 AND SXWT-PC512

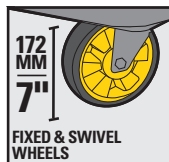

PRODUCT CODE	BARCODE	CAPACITY	WEIGHT	FOLDED / UNFOLDED DIMENSIONS	PLATFORM SIZE	WHEELS
SXWT-PC510	8717496635105	150 KG	10 KG	740 MM X 470 MM X 250 MM 740 MM X 470 MM X 900 MM	740 MM X 470 MM	102 MM TPR
SXWT-PC511	8717496635112	250 KG	17 KG	900 MM X 610 MM X 330 MM 900 MM X 610 MM X 1010 MM	900 MM X 610 MM	172 MM TPR
SXWT-PC512	8717496635129	350 KG	18,6 KG	900 MM X 610 MM X 390 MM 900 MM X 610 MM X 1030 MM	900 MM X 610 MM	172 MM TPR

PLYWOOD MOVING DOLLIES

Extra strong plywood dollies for heavy moving applications. The dollies feature an outer plastic bump guard so you do not scratch any walls when moving. This dolly can be used up to 200 Kg. It has a built-in carry on handle for easy positioning and that makes it easy to move the dolly where you need it.



SXWT-MS572

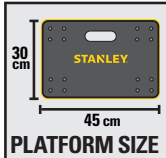

SXWT-MS573

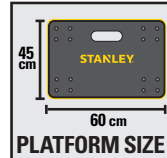
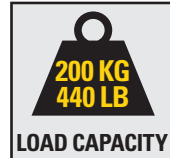

PRODUCT CODE	BARCODE	CAPACITY	WEIGHT	OVERALL DIMENSIONS	PLATFORM SIZE	WHEELS
SXWT-MS572-SP	8717496635723	200 KG	2,7 KG	450 MM X 300 MM X 125 MM	450 MM X 300 MM	76 MM NYLON
SXWT-MS572-PDQ	8717496635761					
SXWT-MS573-SP	8717496635730	200 KG	4 KG	600 MM X 450 MM X 125 MM	600 MM X 450 MM	76 MM NYLON
SXWT-MS573-PDQ	8717496635778					



UTILITY PLATFORM DOLLIES



CONFIGURATIONS

Combine multiple platform dollies to create a platform that suits your needs.

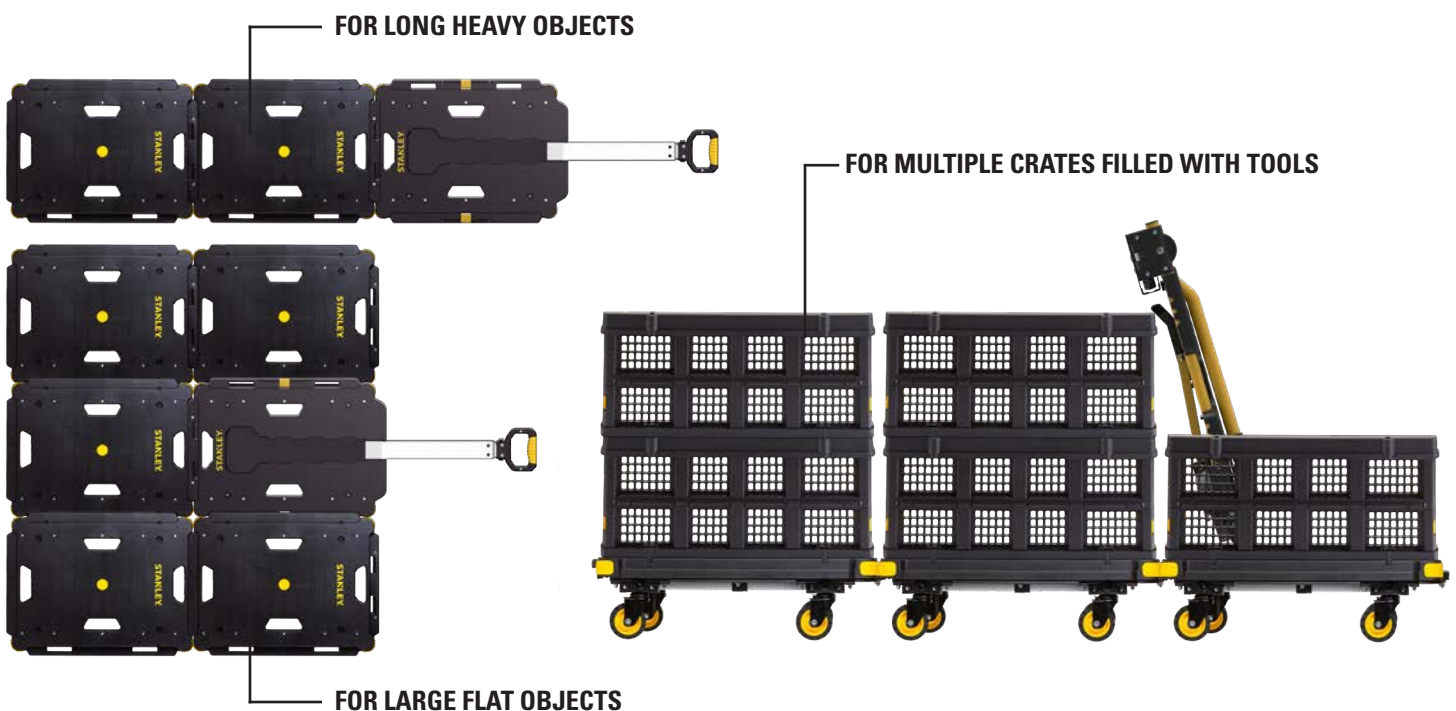

UTILITY PLATFORM DOLLIES

Patented, 4-wheeled Utility Platform Dolly.
Takes only Seconds to Open and Close. Major plastic stress points are made of ultra-durable nylon; other plastic pieces are Polypropylene. Fits virtually anywhere for storage. Tubing material of aluminum and stainless steel.

SXWT-PC531B: This Combi Pack includes the SXWT-PC531 Utility Platform Dolly and SXWT-FT505 Folding Utility Basket

SXWT-PC531

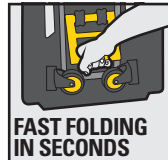
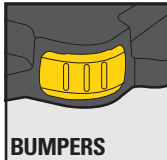

SXWT-PC531B

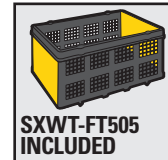

PRODUCT CODE	BARCODE	CAPACITY	WEIGHT	FOLDED / UNFOLDED DIMENSIONS	PLATFORM SIZE	WHEELS
SXWT-PC531-SP	8717496637840	137 KG	5 KG	600 MM X 450 MM X 77 MM	600 MM X 450 MM	75 MM TPR
SXWT-PC531-PDQ	8717496638069			600 MM X 450 MM X 167 MM		
SXWT-PC531B-SP	8717496638267	137 KG	5 KG	SEE SPECIFICATIONS OF SXWTD-PC531 AND SXWTD-FT505	600 MM X 450 MM	75 MM TPR
SXWT-PC531B-FCB	8717496638267					

UTILITY PLATFORM DOLLIES

Patented, 4-wheeled Utility Platform Dolly.
Takes only Seconds to Open and Close. Major plastic stress points are made of ultra-durable nylon; other plastic pieces are Polypropylene. Fits virtually anywhere for storage. Tubing material of aluminum and stainless steel. Extendable Handle for easy manoeuvring.

SXWT-PC532B: This Combi Pack includes the SXWT-PC532 Utility Platform Dolly and SXWT-FT505 Folding Utility Basket

SXWT-PC532

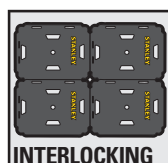
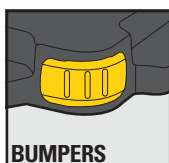

SXWT-PC532B

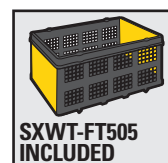

PRODUCT CODE	BARCODE	CAPACITY	WEIGHT	FOLDED / UNFOLDED DIMENSIONS	PLATFORM SIZE	WHEELS
SXWT-PC532-SP	8717496638045	137 KG	5,6 KG	620 MM X 450 MM X 77 MM	620 MM X 450 MM	75 MM TPR
SXWT-PC532-PDQ	8717496638052			620 MM X 450 MM X 1730 MM		
SXWT-PC532B-SP	8717496638274	137 KG	5,6 KG	SEE SPECIFICATIONS OF SXWTD-PC532 AND SXWTD-FT505	620 MM X 450 MM	75 MM TPR
SXWT-PC532B-FCB	8717496638274					



FATMAX PLATFORM TRUCK

Versatile Utility Cart, folds and opens in seconds
 Easy to Use and Store. Comes 100% Fully Assembled
 Compact lightweight design made of durable Aluminum
 Major plastic stress points are made of durable nylon;
 other plastic pieces are polypropylene
 Tubing material of aluminum and stainless steel
 Soft grip handle, platform with basket pin slots
 Includes adjustable handle and pin slots in platform
 for easy and stable double or triple stacking
 Fits virtually anywhere: planes, buses, trains, trunks,
 garages, closets or under furniture for storage

Versatile Utility Cart. Handle folds down independently
 so the cart can be used as a dolly.
 Fully compatible with SXWT-FT505 Folding Utility Basket



FXWT-712

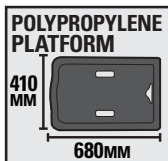

PRODUCT CODE	BARCODE	CAPACITY	WEIGHT	FOLDED / UNFOLDED DIMENSIONS	PLATFORM SIZE	WHEELS
FXWT-712-SP	8717496638076	135 KG	8,5 KG	680 MM X 410 MM X 80 MM	680 MM X 410 MM	100 MM TPR
FXWT-712-PDQ	8717496637277			680 MM X 410 MM X 720 / 820 / 920 MM		

FATMAX PLATFORM TRUCK

Versatile Utility Cart, folds and opens in seconds
 Easy to Use and Store. Comes 100% Fully Assembled
 Compact lightweight design made of durable Aluminum
 Major plastic stress points are made of durable nylon;
 other plastic pieces are polypropylene
 Tubing material of aluminum and stainless steel
 Soft grip handle, platform with basket pin slots
 Includes adjustable handle and pin slots in platform
 for easy and stable double or triple stacking
 Fits virtually anywhere: planes, buses, trains, trunks,
 garages, closets or under furniture for storage

Versatile Utility Cart. Handle folds down independently
 so the cart can be used as a dolly.
 Fully compatible with SXWT-FT505 Folding Utility Basket



FXWT-711

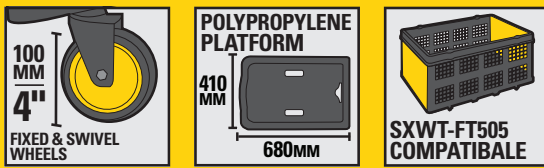

PRODUCT CODE	BARCODE	CAPACITY	WEIGHT	FOLDED / UNFOLDED DIMENSIONS	PLATFORM SIZE	WHEELS
FXWT-711	8717496637116	200 KG	8,5 KG	810 MM X 520 MM X 100 MM 810 MM X 520 MM X 870 MM	810 MM X 520 MM	100 MM TPR

FATMAX PLATFORM TRUCK

Heavy duty design. Steel platform and handle allow for a 300kg load capacity
 Foldable handle: Handle folds down for easy transport and storage
 Oversized flat free PU caster wheels: Solid PU tires cannot spring a leak
 Front wheels swivel for easy cornering
 Oversized 200mm diameter wheels for moving over uneven terrain



FXWT-704

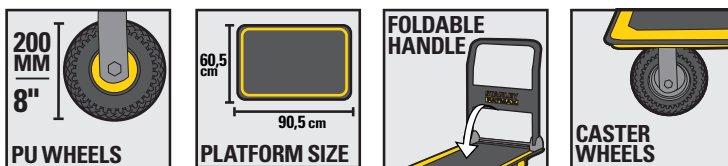

PRODUCT CODE	BARCODE	CAPACITY	WEIGHT	FOLDED / UNFOLDED DIMENSIONS	PLATFORM SIZE	WHEELS
FXWT-704	8717496636737	300 KG	21 KG	905 MM X 605 MM X 365 MM 905 MM X 605 MM X 864 MM	905 MM X 605 MM	200 MM SOLID PU

FATMAX HAND TRUCKS

Professional utility cart
 Folds and opens in seconds
 Easy to use and store. Comes fully assembled
 Rugged lightweight design made of
 lightweight and durable aluminum

Major plastic stress points are made of durable nylon; other plastic pieces
 are polypropylene. Soft grip handle. Includes elastic bungee cord

FXWT-707: Adjustable handles offer knuckle protection
 and fold in for compact storage.

FXWT-705

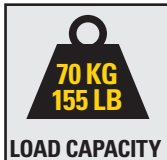

FXWT-706

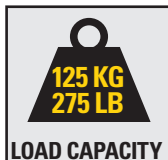

FXWT-707

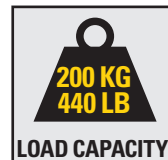

PRODUCT CODE	BARCODE	CAPACITY	WEIGHT	FOLDED / UNFOLDED DIMENSIONS	BASE PLATE SIZE	WHEELS
FXWT-705	8717496636744	70 KG	6,4 KG	390 MM X 56 MM X 710 MM 400 MM X 410 MM X 1000 MM	390 MM X 280 MM	127 MM TPR+PP
FXWT-706	8717496636751	125 KG	7 KG	490 MM X 70 MM X 790 MM 510 MM X 520 MM X 1070 MM	480 MM X 350 MM	175 MM TPR+PP
FXWT-707	8717496636768	200 KG	9,7 KG	600 MM X 90 MM X 1000 MM 600 MM X 600 MM X 1280 MM	590 MM X 400 MM	200 MM TPR+PP

FATMAX HAND TRUCKS

All-in-one design: P-Handle let's truck lay flat.
 Regular handles with knuckle protection.
 Obstacle climbing guides. Extendable load plate.
 Flat-free wheels. Extra wide loading plate.

Fatmax features:
 Standard on all steel trucks: oversized wheel guards, backrest cross-slats, load protectors, high load capacity.
 Flat-free Fatmax FXWT-708 PU wheels.

FXWT-700



FXWT-701

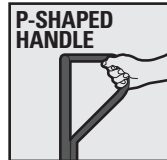
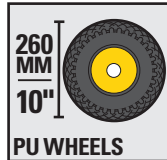

FXWT-702

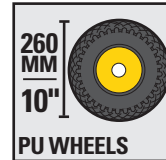

PRODUCT CODE	BARCODE	CAPACITY	WEIGHT	OVERALL DIMENSIONS	BASEPLATE SIZE	WHEELS
FXWT-700	8717496636690	300 KG	16 KG	1280 MM X 550 MM X 470 MM	550 MM X 230 MM	260 MM SOLID PU
FXWT-701	8717496636706	300 KG	13KG	1280 MM X 550 MM X 470 MM	400 MM X 230 MM	260 MM SOLID PU
FXWT-702	8717496636713	300 KG	12,7 KG	1280 MM X 550 MM X 470 MM	400 MM X 230 MM	260 MM SOLID PU



info@keeandgo.com | www.keeandgo.com

